

Item No.	Rated Capacity Cu.Yd	Gate Opening (in)x(in)	Top Opening A (in)	Top Opening B (in)	Loading Height C (in)	Suspended Height D (in)	Overall Height E (in)	Overall Width F (in)	Overall Length G (in)	Pocket CL to CL H (in)	Empty Weight (lbs)
4810	1/3	8 x 8	24	24	39	43	44	47	34	32	380
4814	1/2	8 x 8	24	24	47	51	52	47	34	32	400
4820	3/4	10 x 10	30	30	50	60	62	52	40	38	520
4828	1.0	10 x 10	36	36	54	64	66	58	46	44	640
4840	1 1/2	10 x 10	37	36	66	76	78	60	46	44 3/4	700
4860	2.0	10 x 10	48	48	69	79	81	71	58	56	740

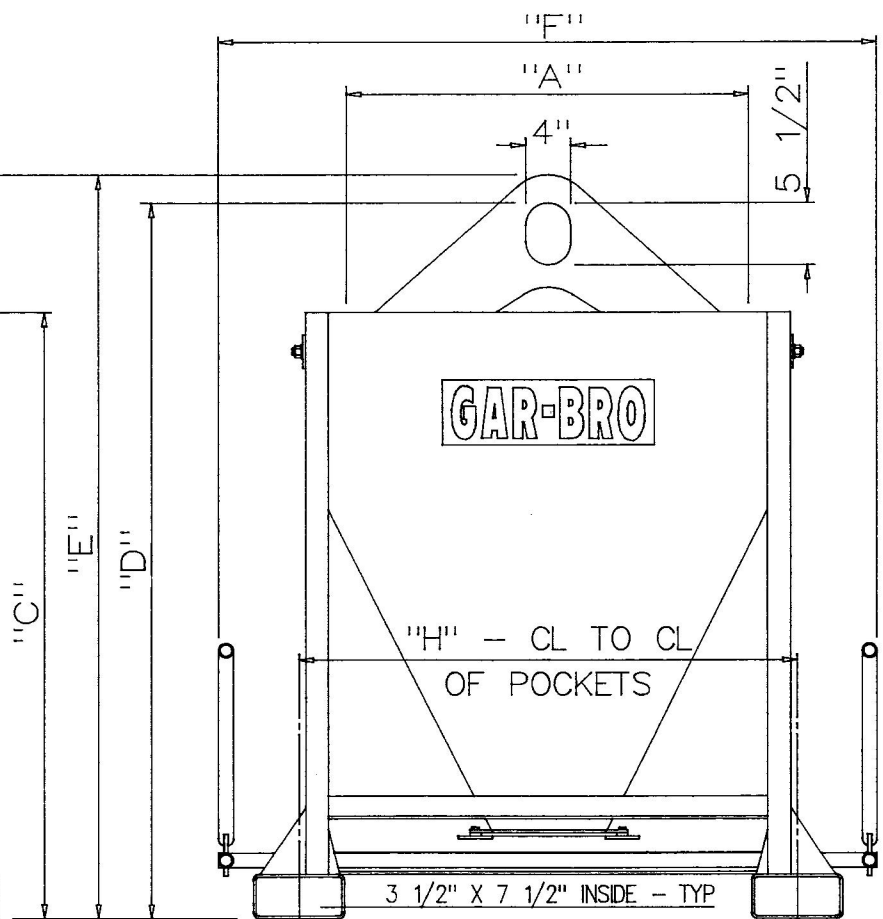
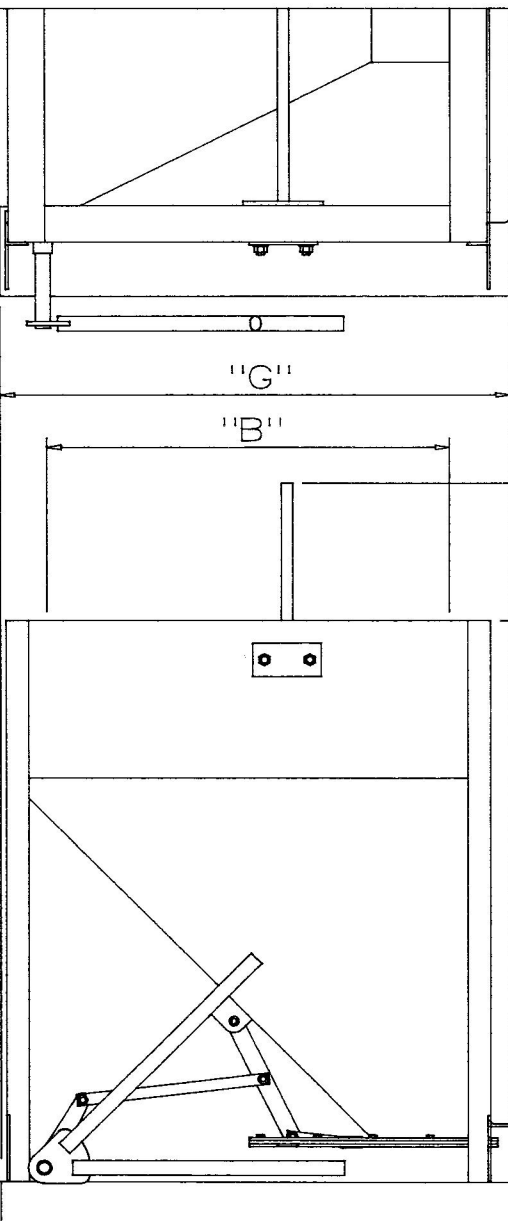
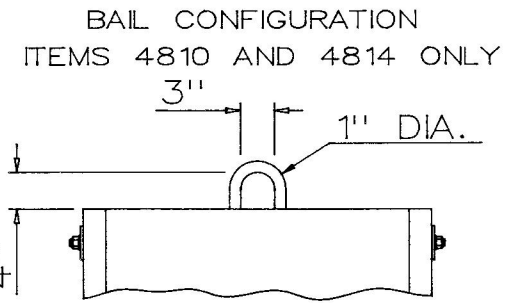

GAR-BRO MANUFACTURING CO.
104 BOLTON SULLIVAN DRIVE P.O. DRAWER 1077
HEBER SPRINGS, ARKANSAS - 72543-1077

"BOND BEAM" BUCKETS
with
VERTICAL FRONT CONE
SLIDE TYPE GATES
and
OPTIONAL FORK POCKETS

SCALE	NONE	SHOP NO.	SALES
DATE	2-23-04	SHIPPING CUBICS	
REVISED		DRAWING NO.	
MADE BY	DCG	80-53	
CHANGED TO/FROM		SHEET C OF C	
SUPERSEDES			